

Gingerbread Homes

Makes about 10 houses

Biscuits

340g plain flour

1 tsp baking powder

½ tsp salt

3 tsp ground ginger

1½ tsp grated nutmeg (optional)

2 tsp ground cinnamon (optional)

225g unsalted butter, softened

340g soft brown sugar

1 egg, beaten

Icing

225g icing sugar



1. Sift the flour, baking powder, salt and ginger together (and the nutmeg and cinnamon if using) into a large mixing bowl.
2. Beat together the softened butter and sugar in a second bowl. Slowly add the beaten egg, so the mixture doesn't curdle.
3. Gently stir in the sifted flour to make a dough. You might need to use your hands to bring it together, but don't over work it.
4. Roll the dough out between a layer of clingfilm and baking paper, to the thickness of a pound coin. Refrigerate for an hour.
5. Pre-heat the oven to 180C.
6. Cut out the biscuits using the template. Cook for 9-10 minutes. When the biscuits come out of the oven they may have spread. Use the templates to trim to size and allow to cool
7. Make the icing with icing sugar and 35ml of water. Add the water slowly and stir to get a stiff gluey consistency. Construct the house starting with sides and front, then glue on the back and the roof. Using any excess icing, sweets and, sprinkles to decorate.

**FRONTIER
YOUTH TRUST**
HOME FOR PIONEER
YOUTH WORK

Templates

Templates can also be printed from our website, fyt.org.uk/blog

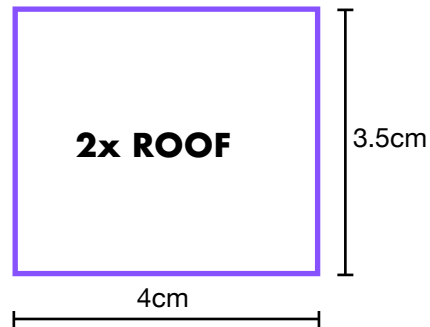
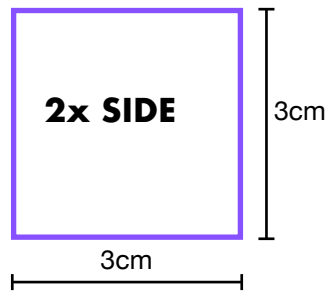
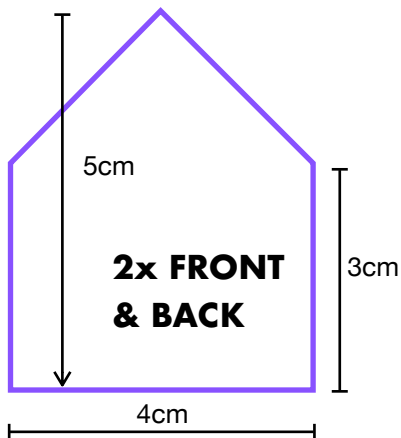

Baking with young people

One way to run this with young people would be to complete steps 1-4 yourself and then get young people to cut, bake and construct. If you want to divide up the dough ready for the young people to cut up, it takes about 90g of dough to make a house.

The biscuits will be very hot coming out of the oven - make young people aware when they come to trimming the biscuits.

A competition for the best made house would be a possible to do remotely over zoom. Either deliver the ingredients, dough or pre-made biscuits and then come together for the construction.

Questions about home

What makes a house into a home?

What would be your dream home?

How do you make someone feel at home?

If God has a room in their house for you, what does it look like?

**FRONTIER
YOUTH TRUST**
HOME FOR PIONEER
YOUTH WORK

